

FK SERIES

ROTATING PULVERIZER WITH KIT
FRANTUMATORE GIREVOLE CON KIT
BROYEUR ROTATIF AVEC KIT
MULTIPROZESSOREN
MULTIPROCESADOR

- ◆ **BUILT IN HARDOX AND STRENX**
COSTRUITO IN HARDOX E STRENX
- ◆ **MULTI PURPOSE WITH INTERCHANGEABLE JAWS**
CHELE INTERCAMBIABILI CON DIVERSE FINALITÀ
- ◆ **QUICK COUPLING SYSTEM**
SISTEMA DI AGGANCIO RAPIDO
- ◆ **INTERCHANGEABLE TEETH**
DENTI INTERCAMBIABILI

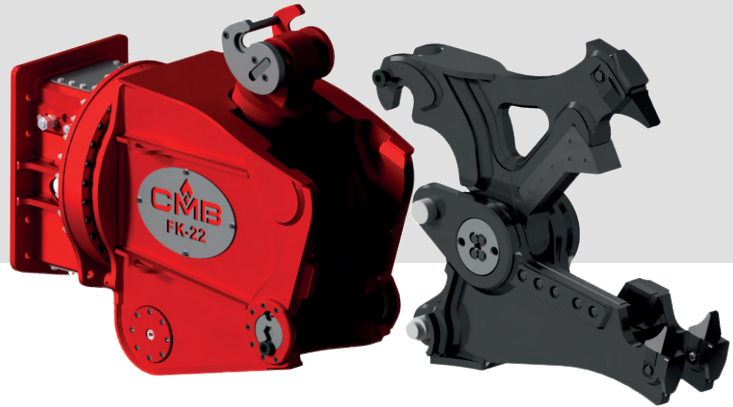

Innovative, versatile, robust and fast. Our FK multiprocessor is composed of a main body which can be quickly coupled with different kits to tackle any job on the construction site.

Innovativo, versatile, robusto e veloce. Il nostro frantumatore girevole multi-kit FK è composto da un corpo principale che può essere velocemente accoppiato a diversi kit al fine di affrontare qualsiasi lavoro in cantiere

- ◆ 4 times reversible blades
- ◆ 360° continuous hydraulic rotation
- ◆ Inverted mounted cylinder
- ◆ Speed valve
- ◆ Lama a 4 profili
- ◆ Rotazione idraulica a 360°
- ◆ Cilindro rovesciato
- ◆ Valvola di velocità

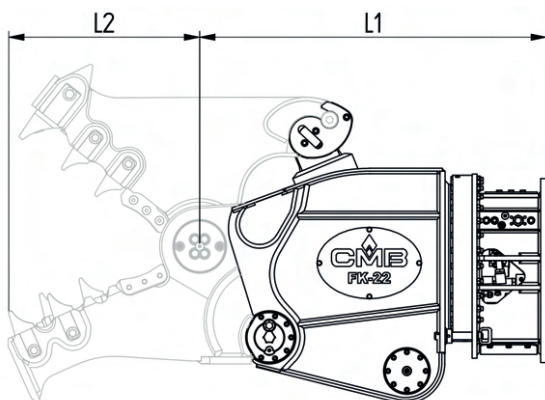

Drain line advised
Drenaggio consigliato

FK series		FK 10	FK 16	FK 22	FK 30	FK 40
BODY WEIGHT	kg	870	1200	1350	1900	2250
EXCAVATOR WEIGHT	ton	10 - 17	17 - 24	23 - 35	32 - 44	45 - 55
L1	mm	1165	1425	1470	1500	1650
EXCAVATOR WORKING PRESSURE	bar	300 - 350	350	350	350	350 - 400
EXCAVATOR OIL FLOW	l/min	200 - 250	250	250	300	350 - 450
ROTATION WORKING PRESSURE	bar	140	120	120	140	140
ROTATION OIL FLOW	l/min	10	20	20	30	40
SPEED VALVE		OPT	OPT	✓	✓	✓

Attachment-excavator couplings data are for information only, always check load diagram of the machine.

I dati relativi agli accoppiamenti attrezzatura escavatore sono da considerarsi puramente indicativi, controllare sempre i diagrammi di carico della macchina operatrice

FH KIT

PULVERIZER

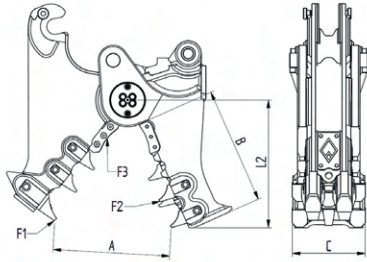

FH kit		FH 10	FH 16	FH 22	FH 30	FH 40
BODY WEIGHT	kg	870	1200	1350	1900	2250
KIT WIEGHT	kg	615	800	1180	1490	1720
TOTAL WEIGHT	kg	1485	2000	2530	3390	3970
L2	mm	770	802	820	980	1070
L tot	mm	1935	2227	2290	2480	2720
A	mm	550	670	750	900	1020
B	mm	620	720	750	840	910
C	mm	415	450	470	560	600
BLADE	mm	120	195	200	300	300
F1	ton	60	80	95	110	135
F2	ton	100	130	150	180	200
F3	ton	150	200	310	340	400
Ø MAX	mm	25	35	45	50	60

CC KIT

COMBI

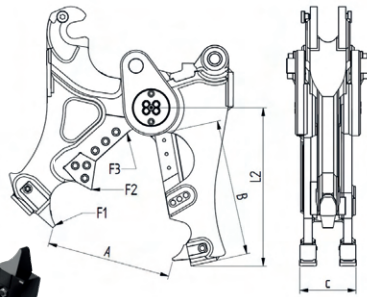
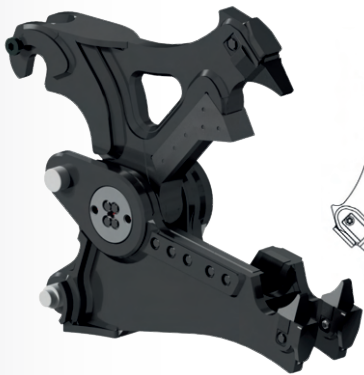

CC kit		CC 10	CC 16	CC 22	CC 30	CC 40
BODY WEIGHT	kg	870	1200	1350	1900	2250
KIT WIEGHT	kg	600	900	1135	1490	2000
TOTAL WEIGHT	kg	1470	2100	2485	3390	4250
L2	mm	760	995	1130	1220	1330
L tot	mm	1925	2420	2600	2720	2980
A	mm	580	670	760	870	980
B	mm	650	800	830	950	1020
C	mm	290	340	380	410	450
BLADE	mm	420	510	605	675	750
F1	ton	55	80	95	120	150
F2	ton	85	110	140	180	210
F3	ton	260	420	580	660	800
Ø MAX	mm	30	35	42	48	55

CR KIT

SHEAR

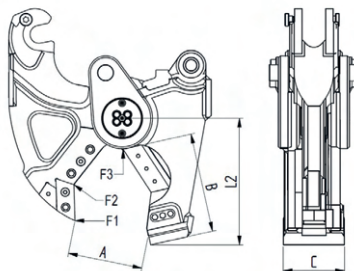

CR kit		CR 10	CR 16	CR 22	CR 30	CR 40
BODY WEIGHT	kg	870	1200	1350	1900	2250
KIT WIEGHT	kg	665	850	1020	1490	1850
TOTAL WEIGHT	kg	1320	2050	2370	3390	4100
L2	mm	600	680	710	840	940
L tot	mm	1765	2105	2180	2340	2590
A	mm	320	380	420	520	575
B	mm	420	520	560	620	700
C	mm	300	330	350	400	430
BLADE	mm	400	480	530	580	620
F1	ton	85	100	140	160	210
F2	ton	120	160	240	325	400
F3	ton	280	300	520	660	715
Ø MAX	mm	35	45	55	70	80
■	mm	30	35	45	50	60
■	mm	8	10	12	16	20
IPE	mm	140	220	300	330	360
HEA	mm	120	160	200	240	280